

SALVAJOR® TroughVeyor®

Job: _____ Item No.: _____

Model TVL



A Water Trough Conveyor and Disposing System

- Model TVL, left hand operation
- Model TVR, right hand operation

Recirculated Water used by the system for scrapping reduces water and sewer costs. The TroughVeyor consumes only 7 gallons of fresh water per minute.

Trough Water Volume with the TroughVeyor is 70 gallons per minute. This volume swiftly propels food waste down the trough and into the disposer with no additional hand movement, leaving both hands free for high-volume scrapping. The TroughVeyor lets you keep up with large conveyor or flight dishmachines.

Design Flexibility is offered by the TroughVeyor as troughs can turn corners. The TroughVeyor's high water volume allows the design of wider, longer troughs allowing you to soak problem dishes or add gusher heads to pre-rinse compartmental trays.

HydroLogic Water Saving Control has an adjustable timer with user friendly LCD readout.

Typical trough layout

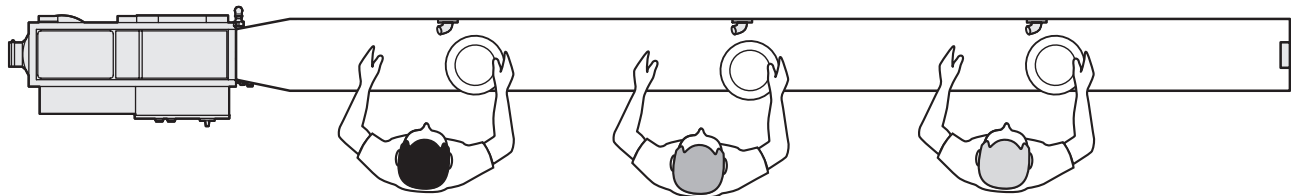

Typical trough layout is 12" wide and 14' in length with up to 3 optional gusherheads spaced 3' - 4' apart to accommodate 3 operators.



TroughVeyor® Model TVL

LEFT HAND OPERATION - WATER FLOWS RIGHT-TO-LEFT

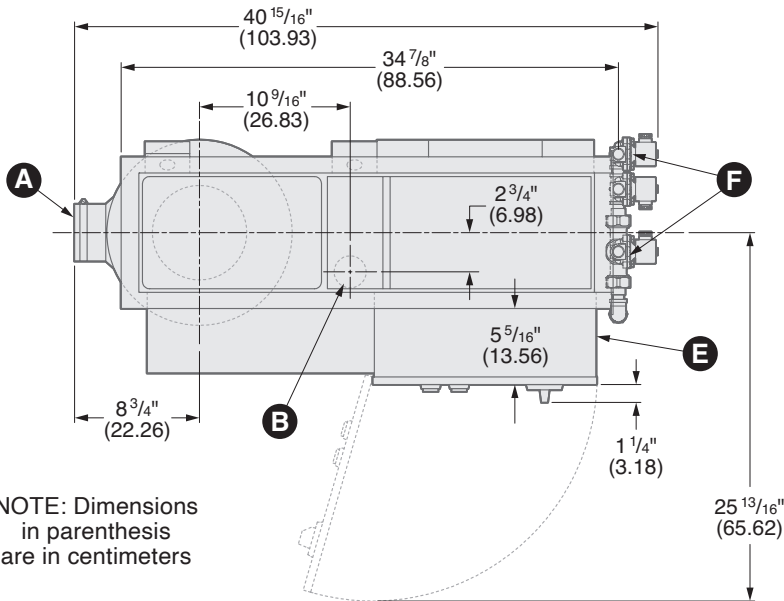

NOTE: Dimensions in parenthesis are in centimeters

Utility Connections

- A** Rubber disposer drain accepts 2" piping or 3" piping by removing drain insert. Disposer drain can be rotated at most any angle by rotating disposer.
- B** Tank reservoir drain – Plumb 2" piping from valve to floor drain or connect to disposer drain piping ahead of P trap.
- C** Disposer electrical connection.
- D** Disposer to control connection.
- E** Incoming electrical connection.
- F** Hot and cold water connection. 1/2" NPT

All connections are to be made by qualified personnel who will observe all local and national codes.

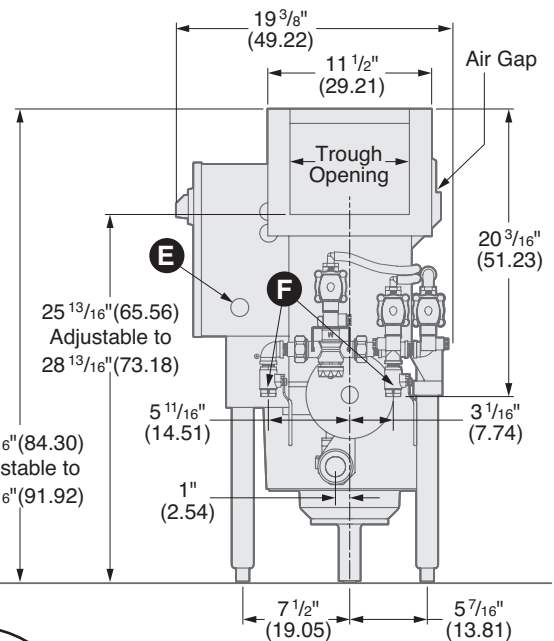
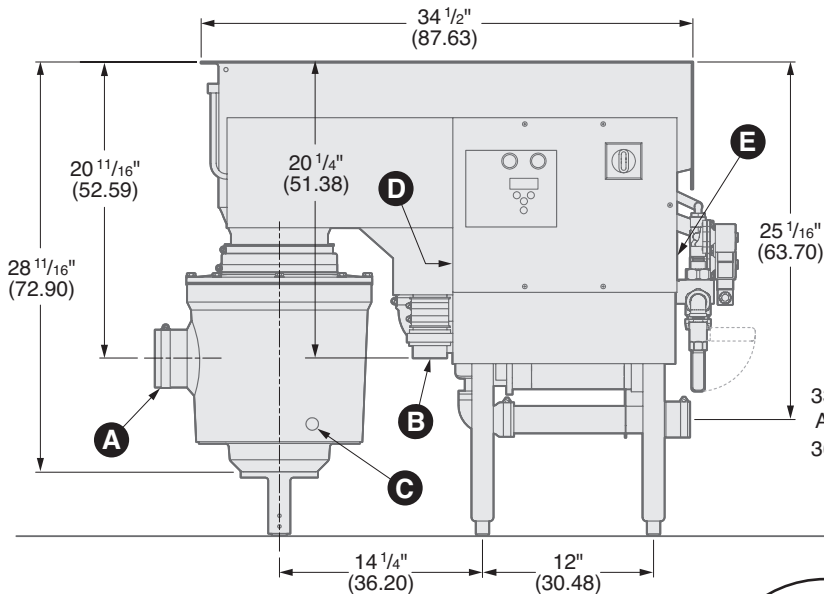
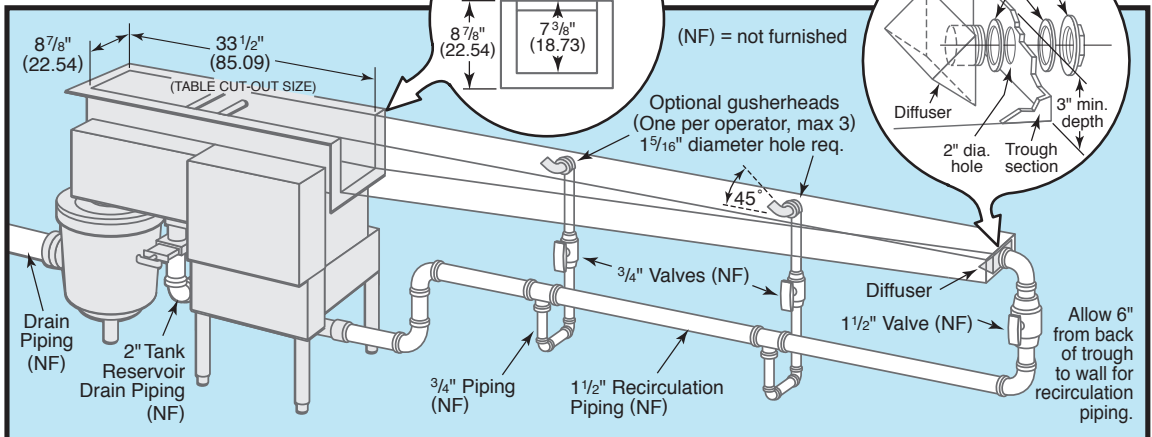
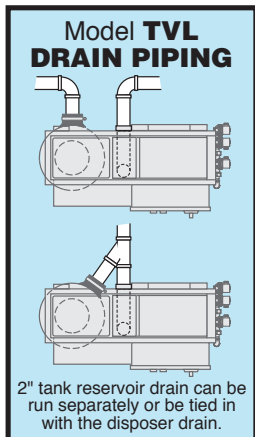

Table cut-out: $8 \frac{7}{8}$ " (22.54) x $33 \frac{1}{2}$ " (85.09)



TroughVeyor® Model TVR

RIGHT HAND OPERATION - WATER FLOWS LEFT-TO-RIGHT



- Trough must have a minimum 3" depth with a fall of at least 3/32" per running foot towards the TroughVeyor.
- Minimum 6" clearance is required from the trough to the wall to allow room for recirculation piping.

NOTE: Dimensions in parenthesis are in centimeters

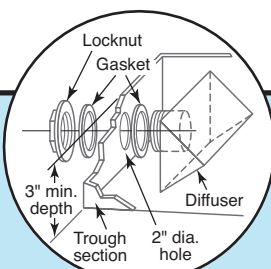
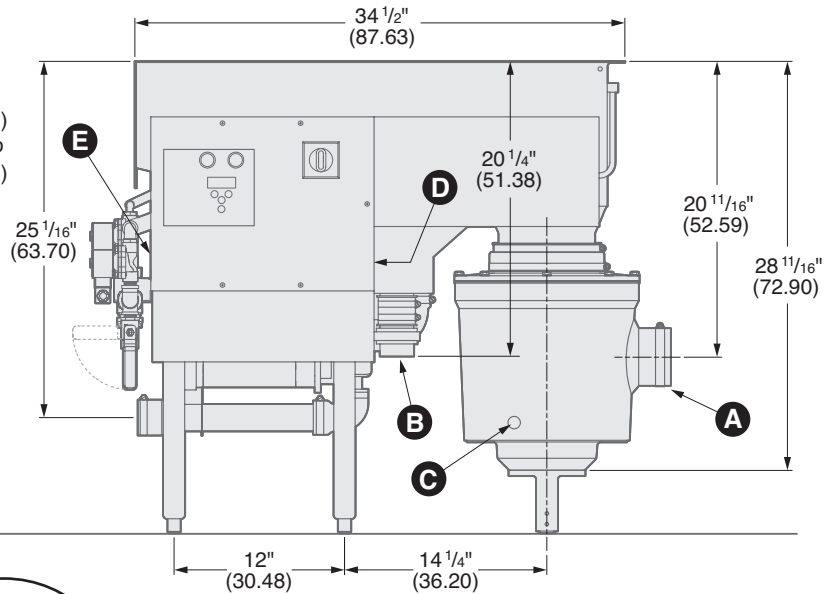
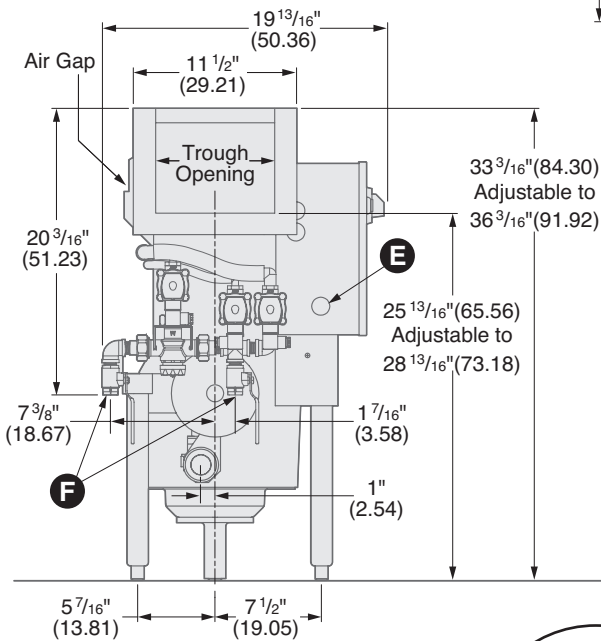
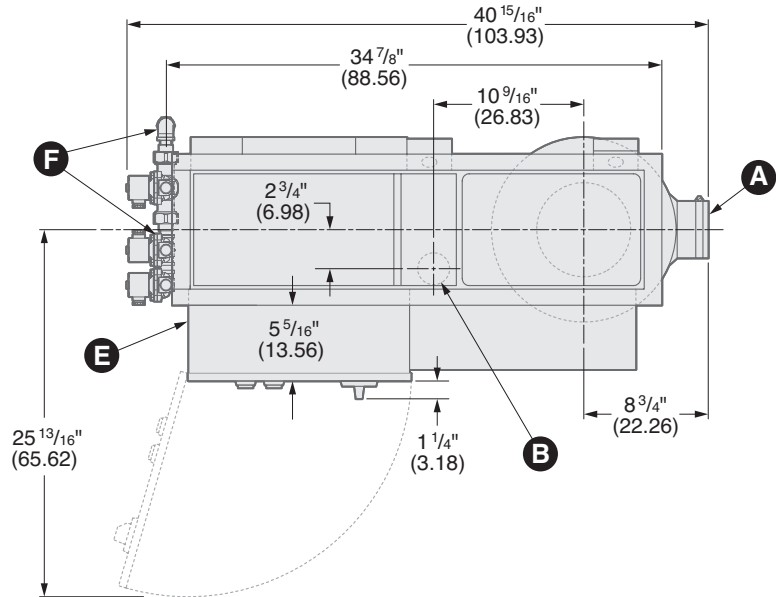

Trough matching flange layout

(NF) = not furnished

Optional gusherheads (One per operator, max 3)
1 5/16" diameter hole req.

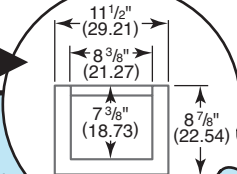
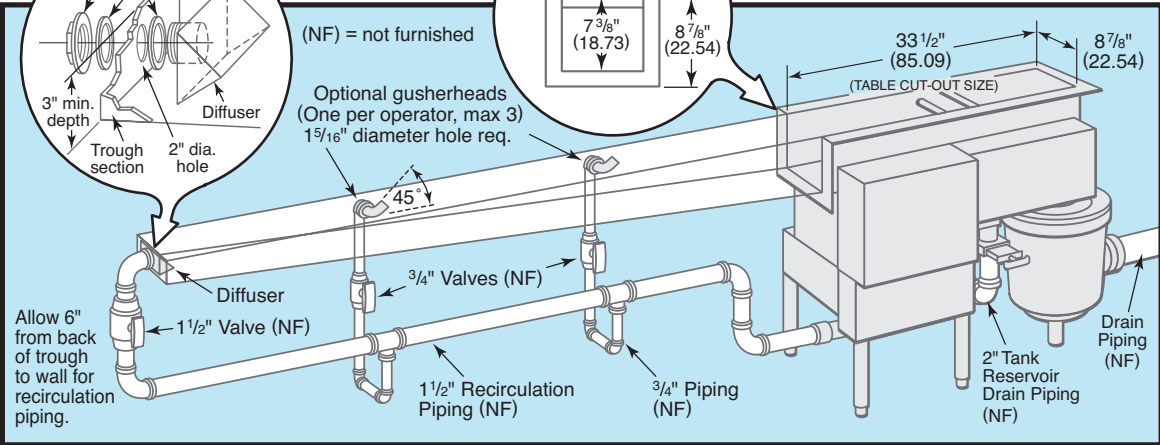
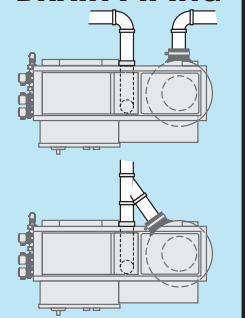

Table cut-out: 8 7/8" (22.54) x 33 1/2" (85.09)



Model TVR DRAIN PIPING



2" tank reservoir drain can be run separately or be tied in with the disposer drain.

TroughVeyor® System

Model TVL & Model TVR Specifications

CONSTRUCTION

- Stainless Steel Components
- Salvage Basin
- Disposer Safety Cover
- Adjustable Legs
- Control Panel

ELECTRICAL

- Pre-wired NEMA 4 Panel
- Watertight Conduit/Fittings
- Separate Component Grounding
- Thermally Protected Motors
- Totally Enclosed Motors
- Line Voltage Disconnect
- Disposer Safety Switch
- 24 Volt Safety Circuitry

PLUMBING

- Corrosion Resistant Components
- Automatic Water Blender
- Solenoid Valves
- Unions
- Check Valves
- Incoming Water Valves
- Non-clogging Pump Design
- Quick Opening Drain Valve

SAMPLE SPECIFICATIONS

Unit shall be TroughVeyor, a complete food waste conveying and disposing system with recirculating water as manufactured by Salvajor.

Model ____ TV__, ____Volts, ____Hz, ____Phase.

Furnished with a pre-wired HydroLogic control panel and Stainless Steel NEMA 4 watertight enclosure.

SALVAJOR®

Manufacturers of Commercial Food Waste Solutions - Since 1944

4530 East 75th Terrace Kansas City, MO 64132-2081, USA

816.363.1030 | Toll Free: 1.800.725.8256 | Service: 1.888.725.8256 | Fax: 1.800.832.9373

sales@salvajor.com | service@salvajor.com | www.salvajor.com

MODELS AVAILABLE

Left-Hand	Right-Hand	Disposer
<input type="checkbox"/> 300 TVL	<input type="checkbox"/> 300 TVR	3 HP
<input type="checkbox"/> 500 TVL	<input type="checkbox"/> 500 TVR	5 HP

ACCESSORIES

- Remote Start-Stop Button
- Remote Mounting Bracket
- Correctional Package
- Gusher Heads
- Stainless Steel Dejamming Prong

VOLTAGES AVAILABLE

(SPECIFY EXACT OPERATING VOLTAGE)

<input type="checkbox"/> 208V	<input type="checkbox"/> 230V	<input type="checkbox"/> 460V, 60 Cycle, 3 Phase
Disposer	3-5 HP	208-230-460V
Pump	¾ HP	208-230-460V
Separator	⅙ HP	208-230-460V

FULL LOAD AMPS

TOTAL FULL LOAD AMPS			THREE PHASE	
MODEL	208V	230V	460/480V	Total HP
300-TV	12.7	11.7	5.9	4
500-TV	17.7	16.2	8.2	6

UTILITIES REQUIRED

208, 230 or 460 Volt, 60 cycle, 3 phase electric service, ¾" hot and cold water supply and reduce to ½" at connection. 2" or 3" waste line, 2" tank reservoir drain.

(Specifications subject to change without notice.)



Disposer
not included
in listing.

Disposer
not included
in listing.