

Food Waste Disposers

Models: 100 - 200 - 300 - 500



JOB: _____

Item No.: _____



SPECIFICATIONS:

MOUNTING – Rubber adaptor above grind chamber and rubber drain outlet isolates sound and eliminates vibration. No metal to metal contact.

EXTERIOR HOUSING – Permanent molded from heat treated, corrosion resistant aluminum alloy then CNC machined to a smooth polished finish. Paint free.

SHREDDER – Machined high strength, wear resistant hardened carbide alloy. Sized to match grinding power with horsepower.

Model	Shredder/Rotor
100	8" w/2 Cutter Bars
200	8" w/4 Cutter Bars
300	9" w/4 Cutter Bars
500	10" w/4 Cutter Bars

ROTOR – Machined high strength, wear resistant hardened carbide alloy. Sized to match grinding power with horsepower.

MOTOR – All motors are totally enclosed. Models 300-500 are fan and water cooled for efficiency and longer life. Models 100-200 are water cooled only. All have built-in manual reset thermal overload protection.

BEARINGS – Tapered roller (top), Sealed ball (bottom).

SEAL – Extended Lip Water Seal.

WASTE OUTLET – Models 100-200 rubber drain accepts 2" piping. Models 300-500 accept 2" or 3" piping by removing drain insert.

DUAL DIRECTION GRINDING – Designed to operate in either direction. Direction of rotation can be controlled when installed with automatic reversing controls. *Reversing rotation can double cutting teeth life.*

ASSEMBLIES – CA – Cone Assembly with 12", 15" or 18" Cone
SA – Sink Assembly with 3½" or 6½" Sink Collar

DISPOSER CONTROLS – MSS: (Non Reversing)
MRSS: (Manual Reversing)
ARSS-2: (Automatic Reversing)
ARSS: (Automatic Reversing with Water Saver)

NEMA 4 Watertight Controls

Optional Line Disconnect (LD) available on MSS, MRSS & ARSS

SINGLE LEG: OPTIONAL			
Models:	100	200	
HP:	1	2	

SINGLE LEG: INCLUDED			
Models:	300	500	
HP:	3	5	

Cone Assembly

TABLE CUT-OUT:
12" CONE - 12 7/8"
15" CONE - 15 7/8"
18" CONE - 18 7/8"

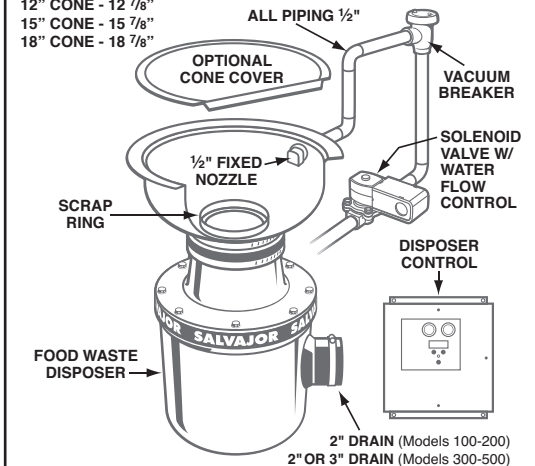

NOTE: INSTALL PER ALL APPLICABLE CODES

Salvajor Food Waste Disposers

D E T A I L S A N D D I M E N S I O N S

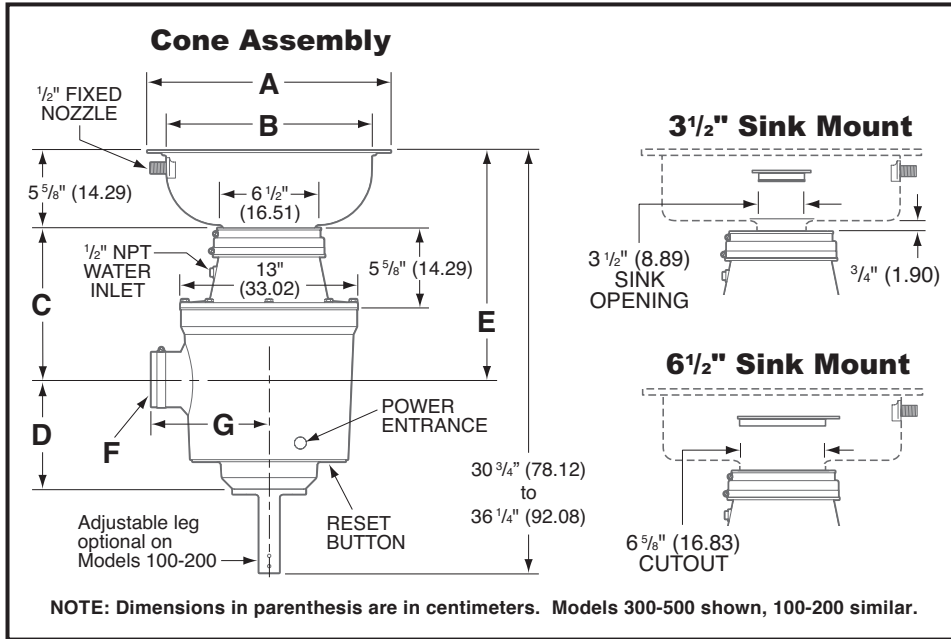

FULL LOAD AMPS

Model 100 (1 HP)		
115 Volts	1 Phase	18.6 Amps
208 Volts	1 Phase	10.2 Amps
230 Volts	1 Phase	9.3 Amps
208 Volts	3 Phase	4.9 Amps
230 Volts	3 Phase	4.5 Amps
460 Volts	3 Phase	2.3 Amps

Model 200 (2 HP)		
115 Volts	1 Phase	24.0 Amps
208 Volts	1 Phase	12.1 Amps
230 Volts	1 Phase	12.0 Amps
208 Volts	3 Phase	6.6 Amps
230 Volts	3 Phase	6.0 Amps
460 Volts	3 Phase	3.0 Amps

Model 300 (3 HP)		
208 Volts	3 Phase	8.8 Amps
230 Volts	3 Phase	8.0 Amps
460 Volts	3 Phase	4.0 Amps

Model 500 (5 HP)		
208 Volts	3 Phase	13.8 Amps
230 Volts	3 Phase	12.5 Amps
460 Volts	3 Phase	6.3 Amps

Cone Dimensions			
	12" Cone	15" Cone	18" Cone
A	14-7/8" (37.78)	17-7/8" (45.40)	20-7/8" (53.02)
B	12" (30.48)	15" (38.10)	18" (45.72)

Dimensions		
	Models 100-200	Models 300-500
C	8-1/2" (21.59)	11" (27.98)
D	7-5/16" (18.57)	8" (20.31)
E	14-1/8" (35.92)	16-5/8" (42.26)
F	2" Drain	2" or 3" Drain
G	8-1/2" (21.59)	8-5/8" (21.96)

(Specifications subject to change without notice)
Current specification details may be found online
at www.salvajor.com

Disposer Models: 100, 200 300, 500 All Controls	Disposer Models: 100, 200 300, 500 All Controls	Disposer Models: 100, 200 300, 500 All Controls

SAMPLE SPECIFICATION			
500-CA-18	ARSS-LD	(208/60/3)	
Model	Cone Size	Disposer Control	Electrical Specs.
Assembly			

◆ SPECIFY EXACT OPERATING VOLTAGE ◆



The Salvajor Company 4530 East 75th Terrace Kansas City, Missouri 64132-2081, USA
1-800-SALVAJOR (816) 363-1030 FAX: 1-800-832-9373
www.salvajor.com Email: sales@salvajor.com service@salvajor.com
Manufacturers of Commercial Food Waste Disposing Systems since 1944